

# Printing

recount  
cloze exercise



## How I made a Lino-Print

Place these words into the spaces below.

lino-block

multiple-copies

mirror-image

First, I drew three squares by tracing around my \_\_\_\_\_ - \_\_\_\_\_ with a pencil.

Next, inside the first square, I made a line-\_\_\_\_\_ of a \_\_\_\_\_ or \_\_\_\_\_ that I remembered from my country.

Inside the second square, I drew a \_\_\_\_\_ of someone I know ... a friend, a relative or even myself.

Then inside the third square, I \_\_\_\_\_ the first two drawings so that I had a **FIGURE IN A LANDSCAPE**.

# I remembered that my Print would be the \_\_\_\_\_ - \_\_\_\_\_ of my drawing.

After that I \_\_\_\_\_ my final drawing onto my lino-block using \_\_\_\_\_.

Now I carefully cut out my picture using a variety of lino-cutting tools.

When I had finished cutting, I spread ink evenly on my block with an ink-\_\_\_\_\_.

Next, I carefully place the inked-block face-down on my paper and transferred the image by rubbing with my fingers.

Finally, when the \_\_\_\_\_ was dry, I coloured it using water-colour inks.

lino printing

cityscape

drawing

roller

landscape carbon-paper combined transferred figure print

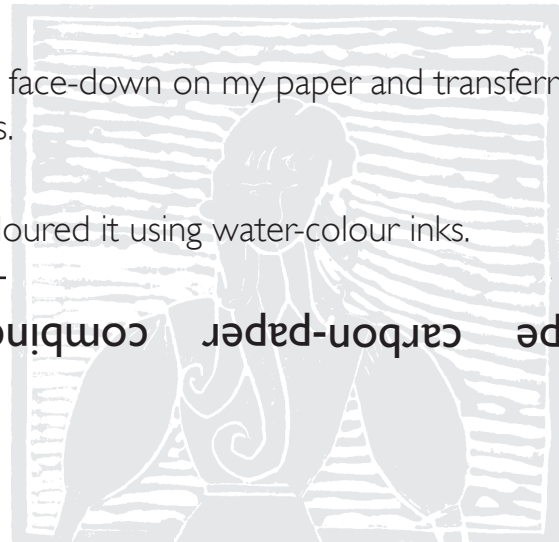

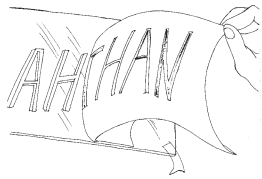

# Printing

vocabulary reinforcement

## X-WORD



across

down

- |  |                                       |
|--|---------------------------------------|
| 3. You put ink on with this.                                     | 1. To move from one place to another. |
| 6. More than one of the same thing.                              | 2. A drawing or painting of a face.   |
| 8. You make the print from this.                                 | 4. To put two things together.        |
| 9. The block and the print are the _____ - _____ of one another. | 5. A drawing or painting of a city.   |
|  | 7. A person or animal in a picture    |

lino printing

The crossword puzzle grid consists of 13 columns and 10 rows. The starting points for the words are as follows:

- 3: Row 2, Column 4
- 4: Row 3, Column 1
- 5: Row 4, Column 10
- 6: Row 5, Column 1
- 7: Row 6, Column 6
- 8: Row 7, Column 5
- 9: Row 8, Column 1

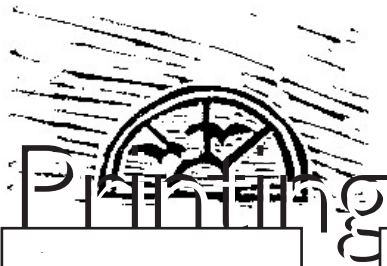

1

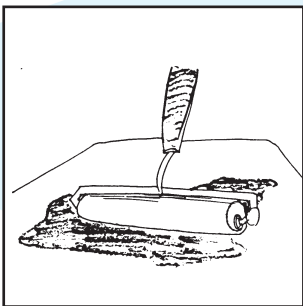
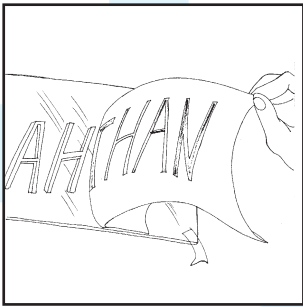
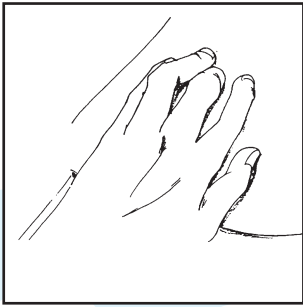
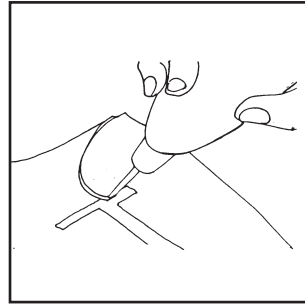
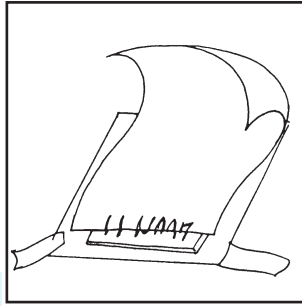
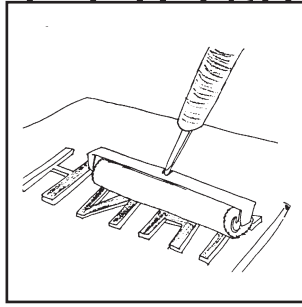
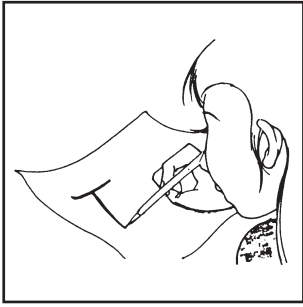

## COMPREHENSION

### sequencing exercise

Match the drawings to the sentences.

1. Than writes her name on a piece of paper. She writes in the mirror image or reverse.
2. She puts carbon-paper between the paper and the lino.
3. Then she traces over her name again.
4. Next she uses a cutting tool to cut her lino-block.
5. She cuts out the parts she wants to be white.
6. After that she spreads the printing ink onto a piece of glass.
7. Then she puts ink on her lino-block with a roller.
8. Next she carefully lays a piece of white paper on the block and rubs it with her fingers.
9. Finally she peels the print off the block.

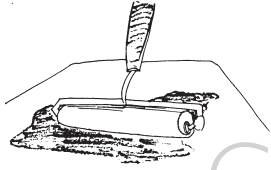

# Printing

## COMPREHENSION

### cloze exercise

1. Than \_\_\_\_\_ her name on a piece of paper. She writes in the mirror image or reverse.
2. She \_\_\_\_\_ carbon-paper between the paper and the lino.
3. Then she \_\_\_\_\_ over her name again.
4. Next she \_\_\_\_\_ a cutting tool to cut her lino-block.
5. She \_\_\_\_\_ the parts she wants to be white.
6. After that she \_\_\_\_\_ the printing ink onto a piece of glass.
7. Then she puts ink on her lino-block with a roller.
8. Next she carefully \_\_\_\_\_ a piece of white paper on the block and \_\_\_\_\_ it with her fingers.
9. Finally she \_\_\_\_\_ the print off the block.

Place these words into the spaces above.

*writes spreads lays peels puts*  
*cuts out uses puts rubs traces*

